

scm  group

SCM GROUP SPA MORBIDELLI - via Casale 450 I 47826 Villa Verucchio, Rimini - Italy
tel. +39 0541 674111 - fax +39 0541 674235 - morbidelli@scmgroup.com - www.scmgroup.com

 morbidelli

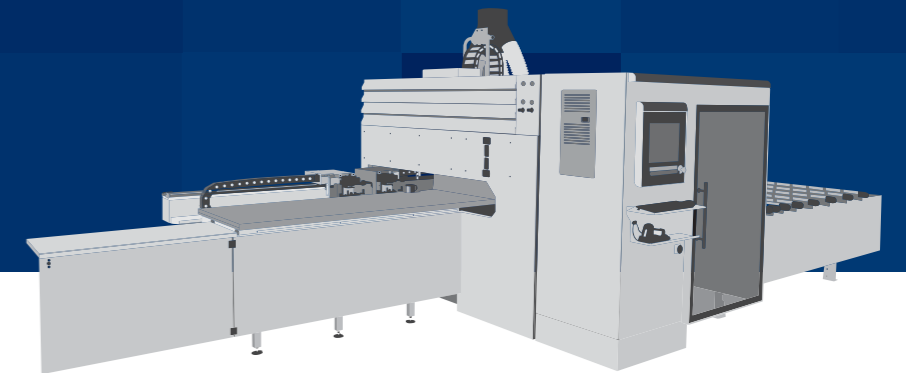

00L0234117B

REV. N. 00 - 04.2015 - MIC STUDIO - 

uniflex

CNC Machining centre for flexible boring, routing and hardware insertion

uniflex

the professional drilling

Working centre realized to satisfy all the operations of **boring, routing, cutting and hardware insertion**, the only one in which the high efficiency of a through-feed boring machine joined to the maximum flexibility of a working centre lead to the maximum performance. Uniflex is equipped with upper and lower units **to allow simultaneously working on the opposite faces**. Thanks to the highest versatility and to the different displacement systems of the pieces with automatic loading-unloading devices Uniflex can work integrated in line or as stand-alone machine.

- **Eliminates machine set-up times**, thanks to the displacement of the 2 independent clamps;
- **Excellent drilling capacity on the 6 faces of the panel**, with opposed machining heads (LOWER and UPPER);
- **Simple and practical to use**, dedicated and powerful software for increased optimisation of the machining phases. The highest levels of productivity achieved with the minimum number of spindle down strokes.

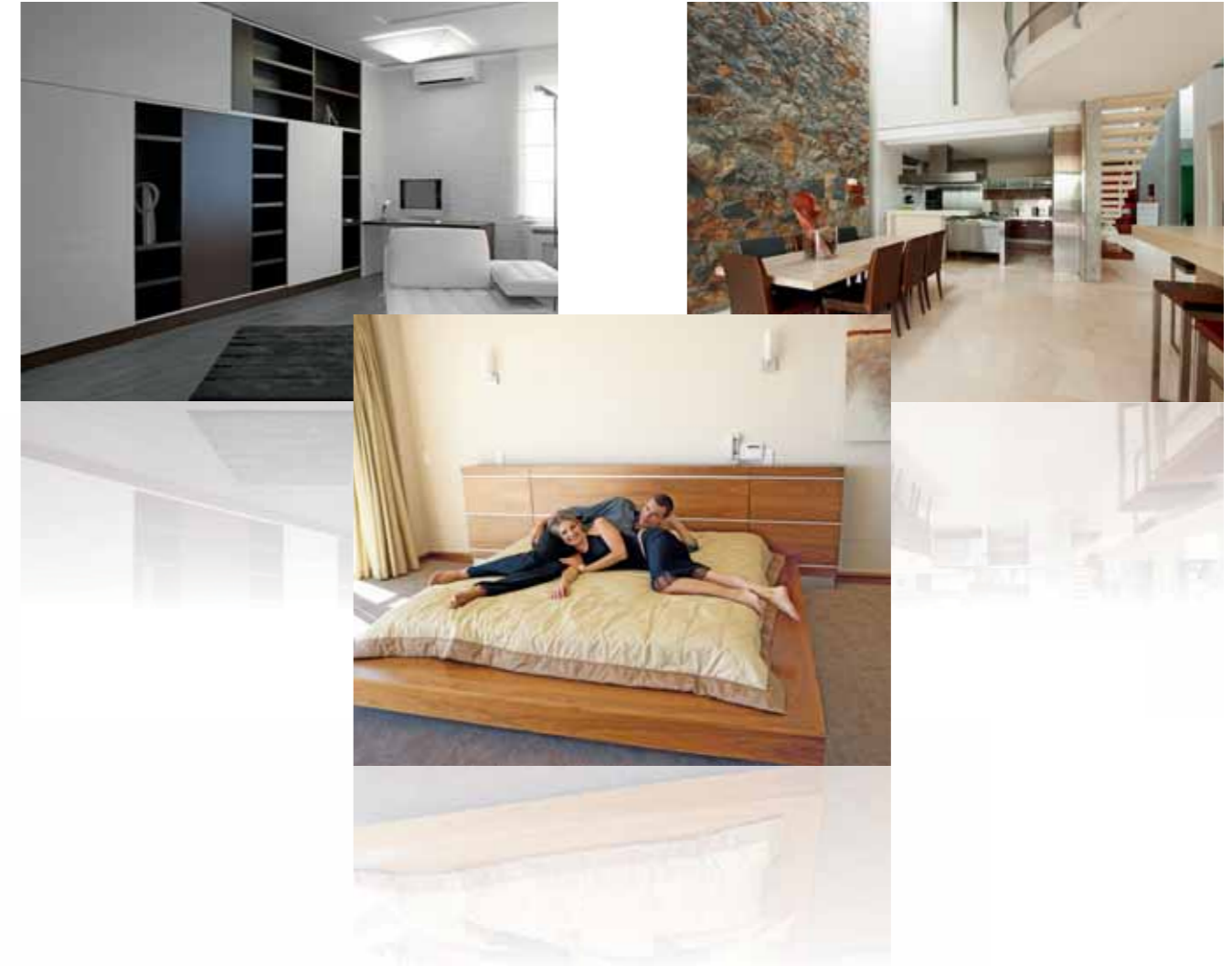

Arc-welded O-frame closed structure guarantees maximum rigidity of the machining heads in order to achieve the best quality finish of the workpiece.

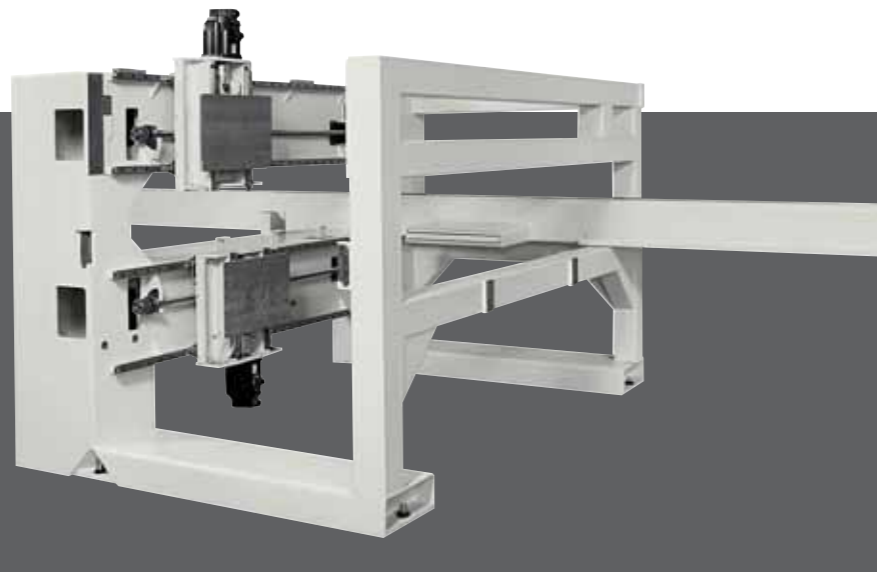

and the one and only

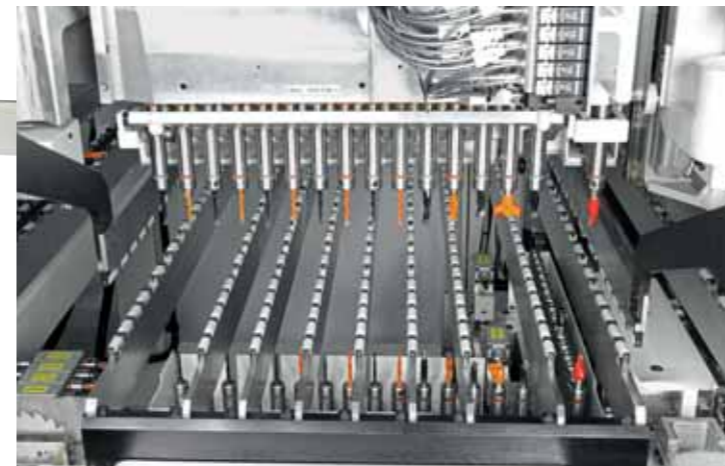

Latest generation boring heads with RO.AX technology (Rotoaxial spindle technology): up to 136 independent spindles.

Zero Backlash with the new RO.AX technology (Rotoaxial spindle technology) that ensures perfect boring. The most efficient spindle on the market.



The panel hold-down grippers with X independent movement allow drilling and routing operations also in positions inside the gripper area thanks to new geometry, optimizing the re-clamping of the workpiece, reducing the cycle times and allowing to process on all 6 faces of the panel.



The 3 pneumatic pressure devices equipped with support rollers guarantee the perfect reference of the panel on the work table next to the area of X and Y horizontal boring, assuring the accuracy of Z quote.



The work table is designed to perform all machining operations in the spaces between the supports. It is made of special rollers in a scratch resistant material, it guarantees the careful movements of the panels to ensure that the panel surfaces are not scratched. Rigid pressers at the infeed and outfeed to the work area, guarantee the positioning of the workpiece during the machining phase.

The two guides and the Brushless motors combined with the rack and pinion kinematic mechanism, offer rigid movement and precise positioning (+/- 0.005) with positioning speeds up to 120 met/min.



Highest versatility according to the customer's requirements, with various types of loading and unloading systems available for the UNIFLEX, when used as a stand-alone machine or inserted in production cells:

- FLOTEX table for manual loading;
- longitudinal and transversal roller conveyors for automatic loading and unloading;
- automatic loading and unloading devices (cells).

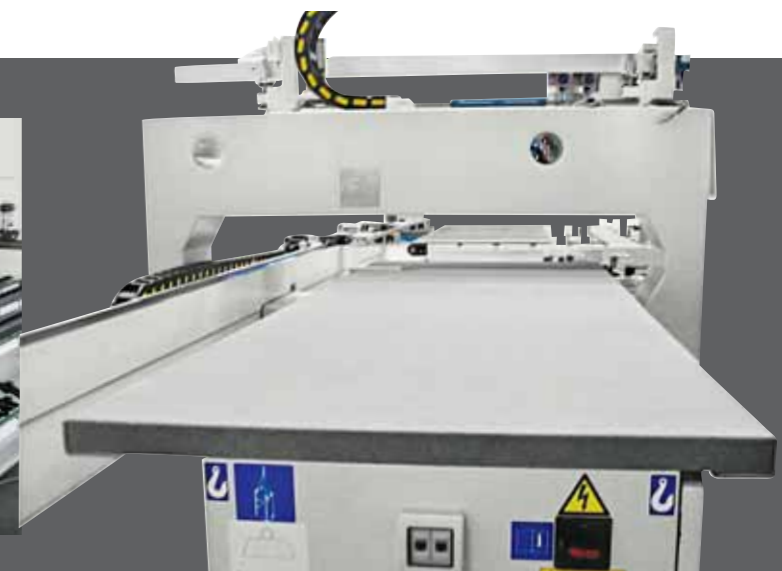

uniflex

Maximum productivity and high customisation



MACHINING HEADS FOR ANY PRODUCTION REQUIREMENT

- Integrated saw blade unit fixed in the X direction with tool Ø 120mm;
- Automatic saw blade unit 0/90° with tool Ø 160mm, also suitable to fit 1 bit;
- 6,6kW electro-spindle (S1) with HSK 63 tool holder;
- Integrated drilling unit for hinges



It is possible to install:

- 2 additional spindles with 32mm step side clamps
- Dowels inserting units. The supply of the dowels is driven by a vibrator feeder and it includes the high pressure vinyl glue feeding unit.



uniflex

Create your uniflex to meet your needs

UNIFLEX S

Essential and complete equipment on two symmetrical heads to cover all requirements:

- up to 31+31 independent vertical spindles;
- up to 10+10 independent horizontal spindles;
- 1+1 Fixed saw blade unit

Optional for a complete machining on 6 faces

- 1+1 automatic saw blade unit 0/90° and horizontal boring (side clamp)
- 1+1 Electrospindle of 4,4 kW ISO30 or 7,5 kW HSK63F
- 1+1 dowels inserting on the upper head
- 2 horizontal spindles side clamps on the upper head

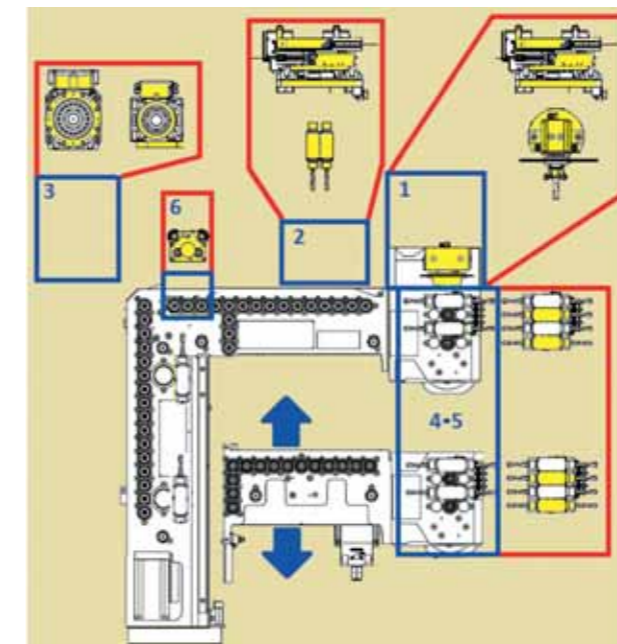
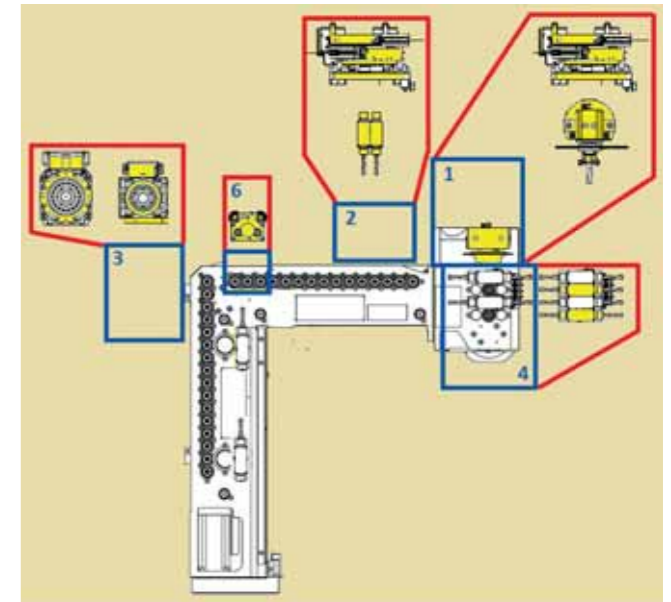

UNIFLEX HP

The maximum boring power on two symmetric al heads with mobile drilling row for fitting and horizontal holes:

- up to 48+48 independent vertical spindles: 14 on mobile unit with adjustable centre to centre distance: min 192mm; max 512mm
- 8+8 independent horizontal unit along X direction with adjustable centre to centre distance
- 2+2 independent horizontal spindles along Y direction (lengthwise)
- 1+1 Fixed saw blade unit

Optional for a complete machining on 6 faces

- 8+8 additional independent horizontal unit with adjustable centre to centre distance:
- 1+1 automatic saw blade unit 0/90° and horizontal boring (side clamp)
- 1+1 electro-spindle of 4,4 kW ISO30 or 7,5 kW HSK63F
- 1+1 dowels inserting on the upper head
- 2 horizontal spindles side clamps on the upper head
- 1+1 Integrated heads for hinges instead of 3+3 vertical spindles

Example of integrated cell:

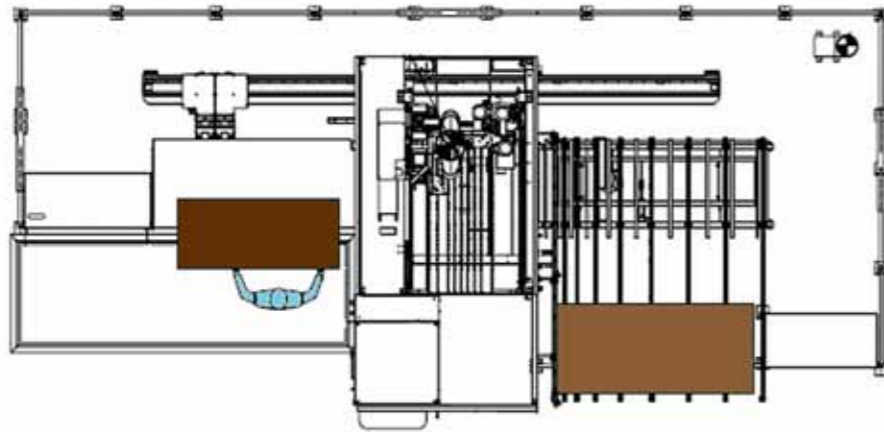

Manual loading and unloading devices

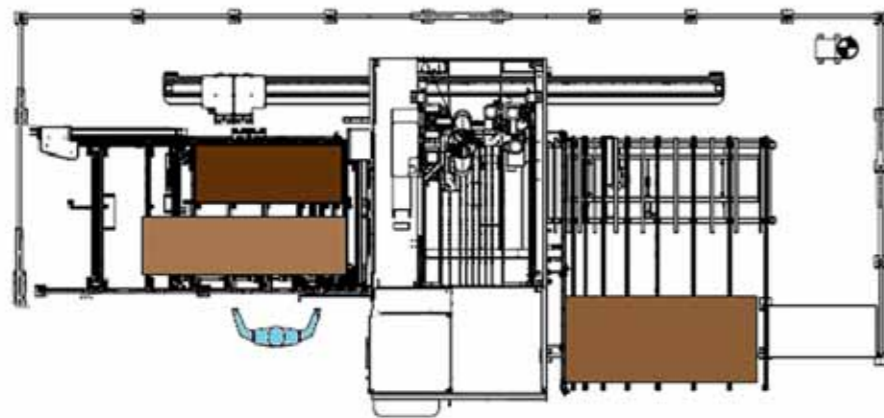

Manual loading at double station and manual unloading

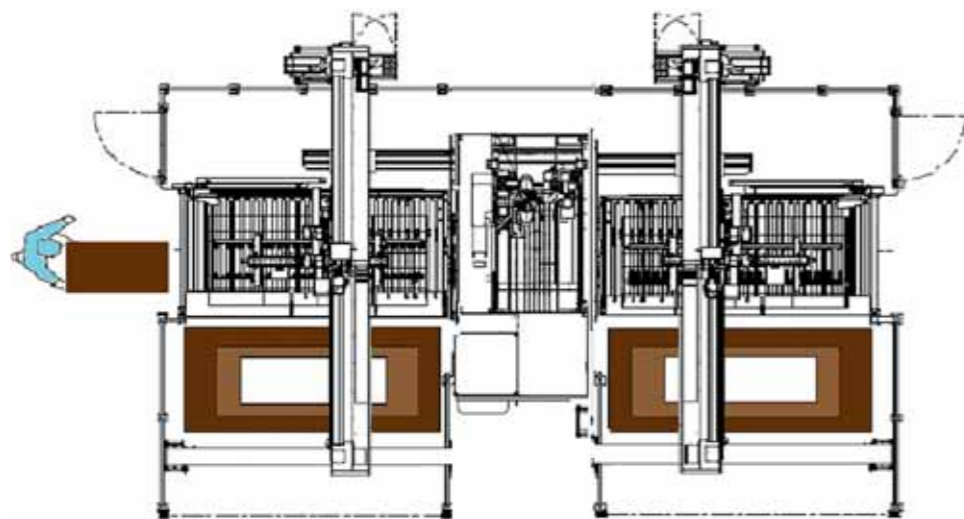

Cell

powerful and easy to use

POWERFUL 'NEW-CONCEPT' NUMERICAL CONTROL, FOR DRILLING-ROUTING MACHINING CENTRES WITH PERSONAL COMPUTER INTERFACE.

PC Office: very familiar and easy to use by the operator for all the machine's operations, with the latest hardware specifications.

The Windows environment forms the basis of the Morbidelli software. Simple and effective, it has been designed by taking the exact requirements of the end-users, whether expert operators or users new to machining centres, through graphic help prompts and specific MACRO.

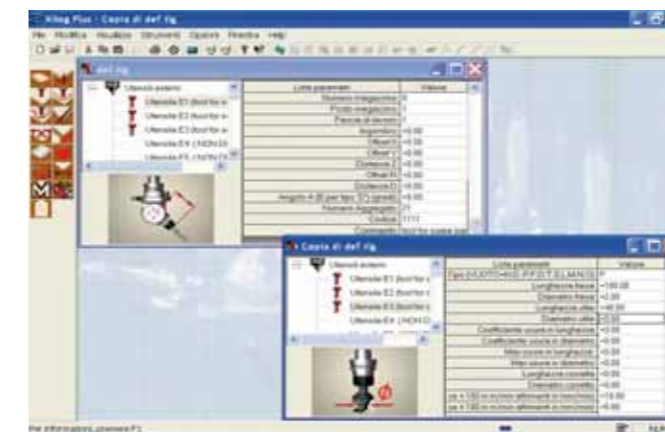

MAIN SOFTWARE FEATURES

- fixturing management with tool display and graphic support to avoid the possibility of entering incorrect data;
- files in DXF format imported immediately and directly;
- dynamic optimized drilling;
- graphic and syntactic help to speed up the data entry operations;
- parametric programming, to automatically update the program when the dimensions of the workpiece being machined are altered, to avoid writing a new program;
- self-diagnosis and warning of any errors or possible failures through alarm messages in the user language, with an online manual to quickly understand and resolve any issues;
- graphic help for the work support positioning to avoid collisions with the tools in the case of through drilling and/or routing as well as to eliminate the empirical tests directly on the machine;
- program execution with barcodes.

uniflex

Technical Specifications

UNIFLEX

Technical Specifications

PANEL DIMENSIONS		
Min. / Max. length panel	mm	250 / 3000
Min. / Max. length panel without panel recovering	mm	250 / 1700
Min. / Max. width panel	mm	70 (120)* / 1300
THICKNESS		
Min. / Max. Single panel thickness	mm	10 / 80
Min. / Max. overlapping panel thickness	mm	5(x2) / 35(x2)
MAX WEIGHT PANEL	Kg	100
WORKING TABLE HEIGHT	mm	950
Z STROKE		
Z stroke upper boring head	mm	145
Z stroke lower boring head	mm	90
PROGRAMMING SPEED		
Clamps programming speed	m/min	120
Head programming speed in Y direction	m/min	35
Head programming speed in Z direction	m/min	30
COMPRESSED AIR INTAKE	Bar	6,5
CONSUMPTION AND DIAMETERS		
Medium compressed air consumption	NI/min	500
Max instant compressed air consumption	NI/min	800
Dust extraction hood diameter – upper head	mm	300
Section air consumption upper head	mc/h	6300
Dust extraction hood diameter – lower head	mm	200
Section air consumption lower head	mc/h	2800
SECTION SPEED	m/s	25
VACUUM	Pa	2500

* 70 mm with manual loading station 120 with automatic loading station

UNIFLEX

layout

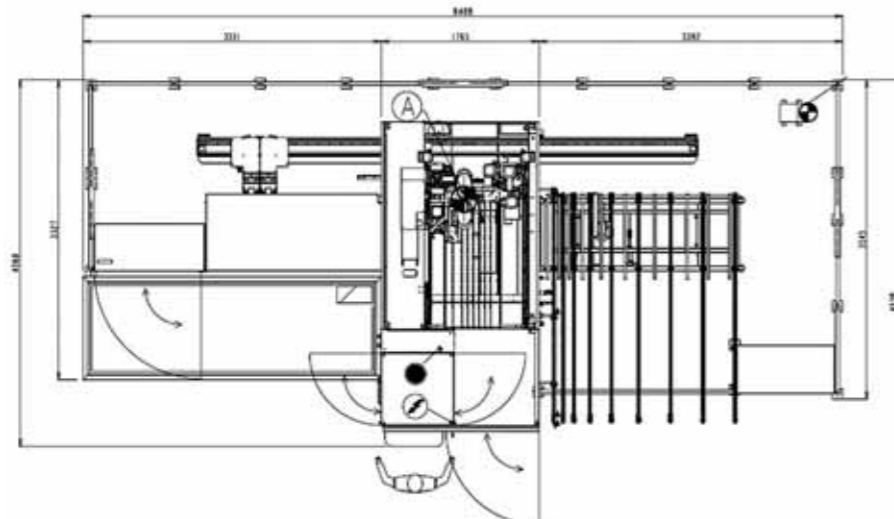

gabbiani
stefani
morbidelli
scm
routech
celaschi
dmc
superfici
sergiani
mahros
cpc
scmgroup
scm
minimax

1 large integrated group
18 production sites
20 foreign branches
 more than **60** years in business
80% exports
350 agents and dealers
360 registered patents
500 support technicians
3.000 square metres of showroom
10.000 classical and professional machines manufactured per year
240.000 square metres of production space

www.scmgroup.com

The technical specifications can vary based on the composition selected. For illustrative purposes certain photos show machines complete with accessories. The technical specifications can be changed without warning and the changes do not affect the safety required by the EC standards.

